

Move Middle School Phase One

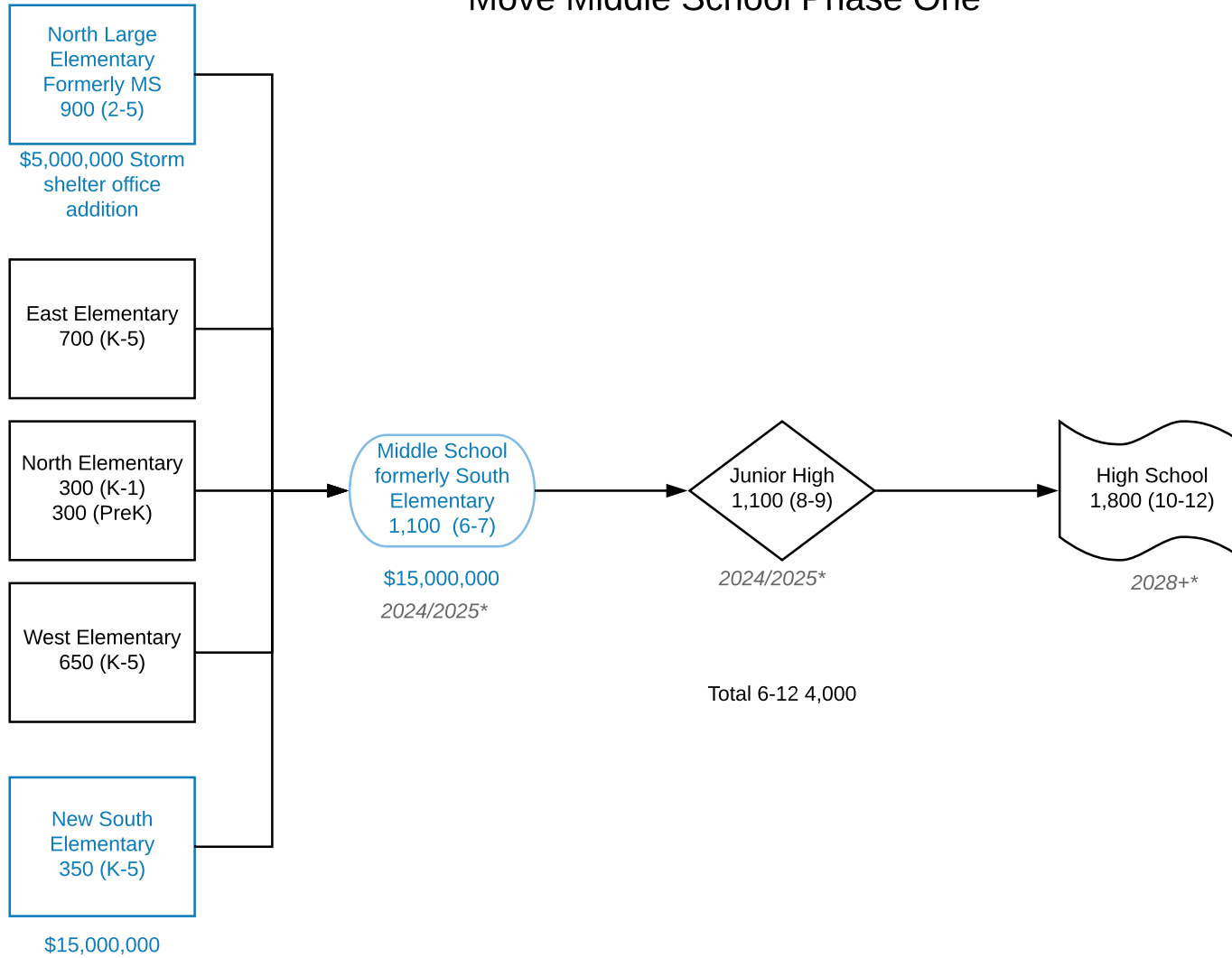

Planning Criteria

1. Safety and Security
2. Desired Class Size, K-12
3. School Sites
4. Special Education
5. Grade Configuration - Freshman Center
6. Early Childhood
7. Modular Classrooms
8. Grade Configuration - Temporary
9. Partnering for Success
10. Grade Configuration - More than 1 grade

Total K-5 2,900
2020/2021*

Total K-12 enrollment 6,900

Phase One Total: \$35,000,000
Total: \$35,000,000

Building capacity based on ideal class size

* Enrollment projections estimated off 2018 Demographic Study. Dates could vary.



Move Middle School Phase Two

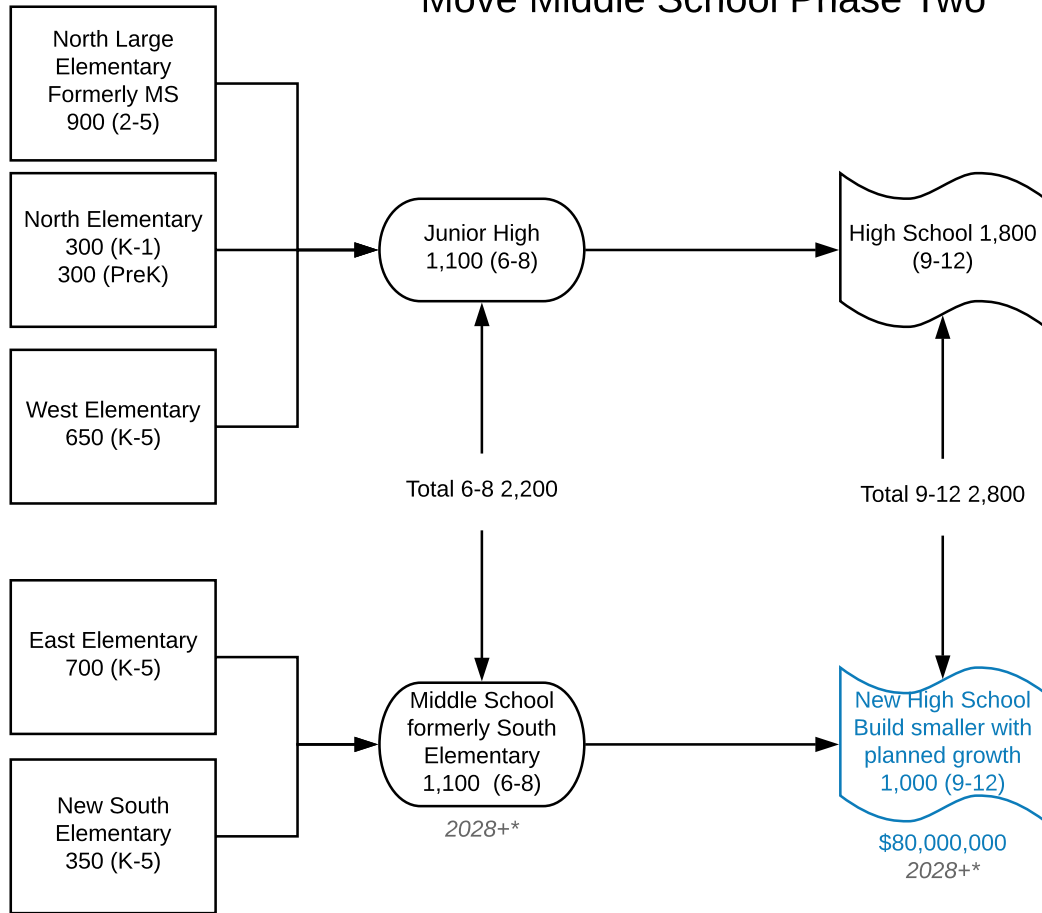

Total K-5 2,900
2020/2021*

Total K-12 enrollment 7,900

Phase One Total: \$35,000,000
Phase Two Total: \$80,000,000
Total: \$115,000,000

Planning Criteria

1. Safety and Security
2. Desired Class Size, K-12
3. School Sites
4. Special Education
5. Grade Configuration - Freshman Center
6. Early Childhood
7. Modular Classrooms
8. Grade Configuration - Temporary
9. Partnering for Success
10. Grade Configuration - More than 1 grade

Building capacity based on ideal class size

* Enrollment projections estimated off 2018 Demographic Study. Dates could vary.



Move Middle School Phase Three

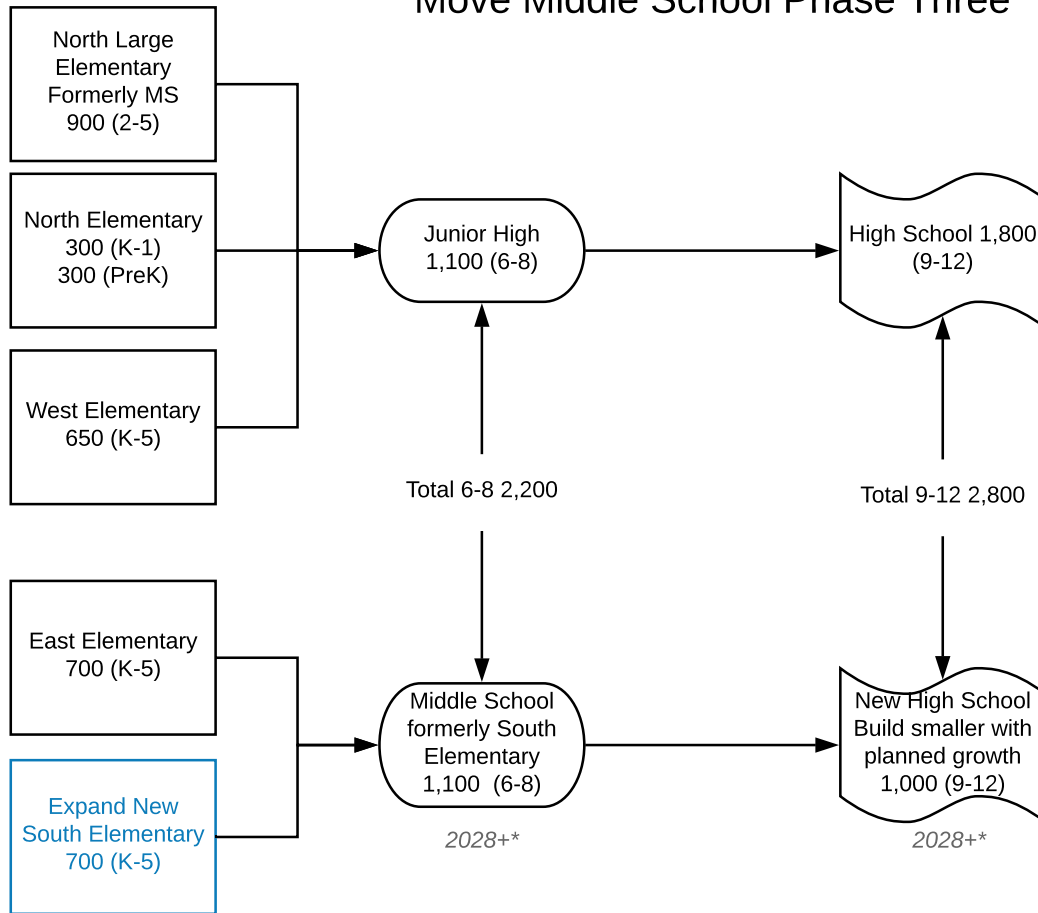

Total 6-8 2,200

Total 9-12 2,800

2028+*

2028+*

\$20,000,000

Total K-5 3,250
2026/2027*

Total K-12 enrollment 8,250

Phase One Total: \$35,000,000
Phase Two Total: \$80,000,000
Phase Three Total: \$20,000,000
Total: \$135,000,000

Planning Criteria

1. Safety and Security
2. Desired Class Size, K-12
3. School Sites
4. Special Education
5. Grade Configuration - Freshman Center
6. Early Childhood
7. Modular Classrooms
8. Grade Configuration - Temporary
9. Partnering for Success
10. Grade Configuration - More than 1 grade

Building capacity based on ideal class size

* Enrollment projections estimated off 2018 Demographic Study. Dates could vary.



Move Middle School Phase Four

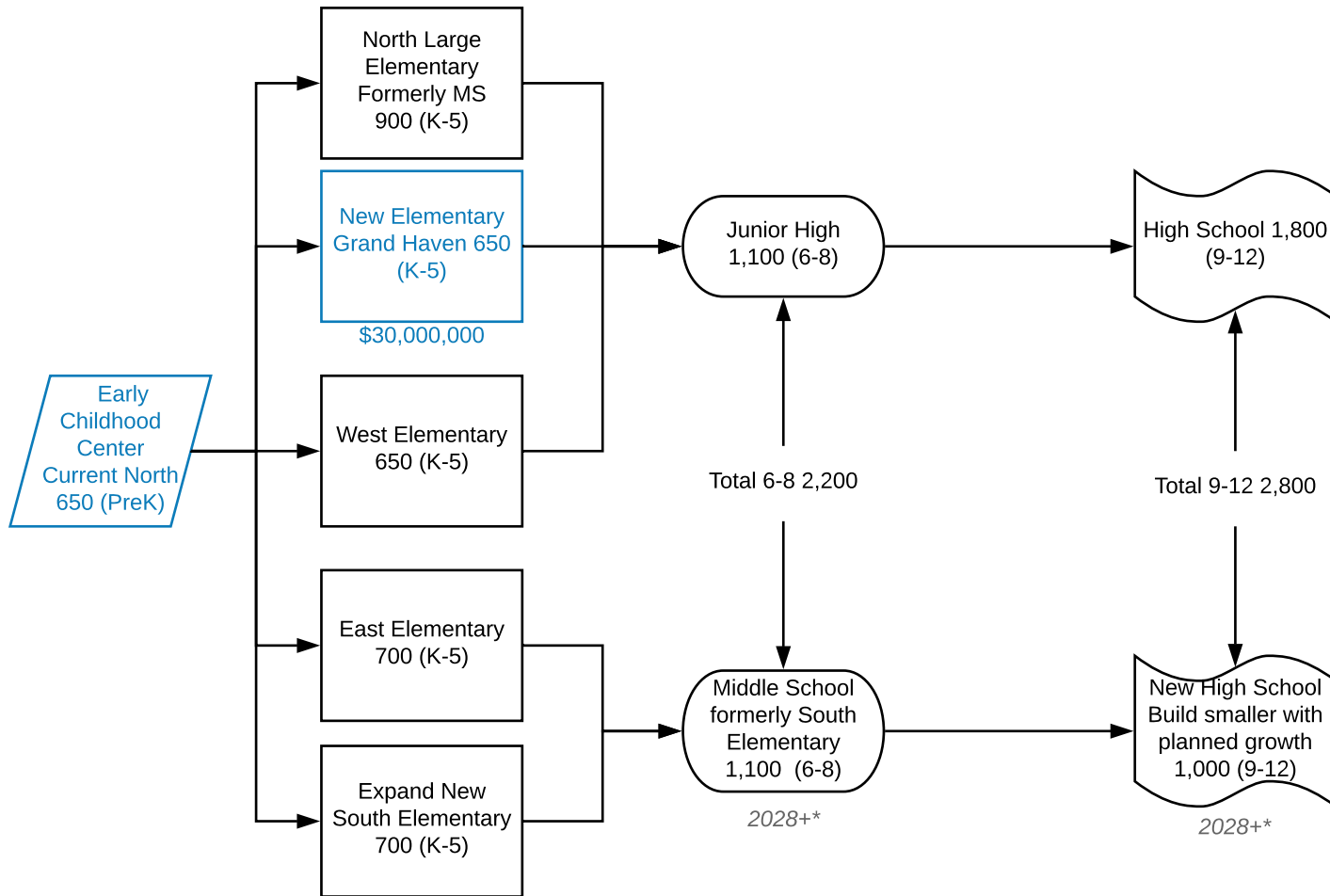

Total K-5 3,600
2028+*

Total K-12 enrollment 8,600

Phase One Total: \$35,000,000
 Phase Two Total: \$80,000,000
 Phase Three Total: \$20,000,000
 Phase Four Total: \$30,000,000
 Total: \$165,000,000

Planning Criteria

1. Safety and Security
2. Desired Class Size, K-12
3. School Sites
4. Special Education
5. Grade Configuration - Freshman Center
6. Early Childhood
7. Modular Classrooms
8. Grade Configuration - Temporary
9. Partnering for Success
10. Grade Configuration - More than 1 grade

Building capacity based on ideal class size

* Enrollment projections estimated off 2018 Demographic Study. Dates could vary.

